

- Briefly operate the direction change-over. The rear light flashes fast 4 times.
- Enter the desired value for CV e.g. a locomotive address.
- Briefly operate the direction change-over. The rear light flashes slowly 4 times. If further CV's are to be programmed repeat points 5-8.

If programming is to be terminated switch the center to "STOP" or set the address to "80" and briefly operate the direction change-over. Since a Motorola digital center from Märklin only accepts inputs of 01 to 80, the value "0" must be entered by entering the address as "80".

Using the page-register to access CV addresses greater than 79

CV-addresses greater than 79 can only be accessed by the page-register. This is CV 66. If a value other than zero is programmed in this CV, then that value, times 64, will be added to the CV address specified by all subsequent writes. The value written into CV 66 must be in range 0 through 64.

The Page register (CV 65) is automatically set to the value zero upon leaving the Motorola** programming mode.

Example

You would like to program CV 82 with the value of 15. First, CV 66 must be programmed with the value 1. Next, program CV 18 with a value of 15. This will have the effect of entering the value 15 in CV 82, since the value of 1 (the contents of CV 66) will be multiplied by 64 (and $1 \times 64 = 64$), and then added to the value specified by the user (18), hence: $64 + 18 = 82$.

Using the offset-register to set CV values greater than 79

CV-values greater than 79 can only be programmed by employing the offset-register. This is CV 65. If a value other than zero is programmed in this CV, then that value, times 4, will be added to the CV value specified by all subsequent writes and then it will be written in the specified CV. The Offset register (CV 66) is automatically set to the value zero upon leaving the Motorola** programming mode.

Example

Consider CV 49 to be programmed for a value of 157. First CV 65 must be set to a value of 25. Now CV 49 must be set to value of 57. The decoder will hold 157 in CV 49, because the offset of CV 65 will be multiplied by 4 ($=100$) and added to 57. After programming, reset the contents of CV 65 to zero in order to avoid unwanted offsets.

Observe: When programming CV 65 and CV 66 the mutual contents are ignored.

Programming with the Mobile Station 1 (Märklin* 60652) (for Uhlenbrock Dec. 76560 and 76420 from version 25)

The Programming Menu in the Loco Menu of the Mobile Station is only available for certain locomotives. Form the Database a locomotive must be selected that is fitted with a programmable decoder.

Use the following procedure:

- Before programming remove all locomotives that are not to be programmed from the track!
- Add a new locomotive and select Part No. 36330. The Display then shows locomotive Ee 3/3.
- Press the "MENU/ESC" button and select the "LOK Change" ("LOK ÄNDERN") column. Here you will find as last function of Register Programming indicated by "REG". Use this function to change the decoder's CV's. You can only write to the CV's with this function.
- Enter the CV number and confirm this with the reversing knob.
- Then enter the value for the CV and confirm this with the reversing knob. The Mobile Station then programs the CV with the desired value.

Programming with the Mobile Station 2 (Märklin* 60652)

Please use the DCC programming menü of the Mobile Station 2

Technical data:

Sound channels:	4
Maxum time duration of sound:	320 Seconds
Power consumption:	up to 160 mA
Size:	17,8 x 11,0 x 4,7 mm

* Märklin is a trade mark of Gebr. Märklin & Cie. GmbH, Göppingen

** Motorola is a trade mark of Motorola Inc. Tempe-Phoenix (Arizona/USA)

#36224 PIKO Sound Modul



Usual for all loco decoders with SUSI interface

Characteristics

- Intelligent sound control with up to 320 seconds of sound buffer
- Comes with speaker and resonating chamber, efficient digital output for 8 Ohm speaker
- Generates the operating (motor) sound of the locomotive, "squealing" brakes, incidental noises while stationary (mechanical devices (e.g. air pumps, etc.))
- Simultaneous replay via 4 independent channels
- 2 sound dependent special function outputs for fire box, steam generator etc.
- 4 custom adjustable sounds
- Maximum 12 additional noises such as whistle, bell, horn, uncoupling or door warning signal and 4 custom sounds
- Function Mapping up to f28
- Shiftable random noise
- Sound changes as engine load changes, such as up/down grade operation; reaction to load change can be adjusted
- The "Smart-Start": When starting the locomotive, the sound module stops the decoder from operating until the actual starting of the vehicle synchronises with the sound of the motor. The locomotive does not move until the very starting sound begins.
- Adjustable volume and audio muting: the sound can be faded or turned off by function key
- Input for hall sensor e.g. for wheel synchronous "chuff" of steam locos or curve squeal for electric and diesel locos
- Up to three modules can be connected to a locomotive decoder, e. g. for multi-engine locomotives
- With solder pads for storage capacitors for break free sound
- Locomotive sounds can be downloaded; various sounds are available at www.uhlenbrock.de

Description

The Intellisound sound module is an auxiliary module for locomotive decoders with the standardized SUSI interface, and can be identified by the appropriate logo. The sound modules supply original, faithfully reproduced sounds of real locomotives. Using "intelligent sound control" the sounds produced are adapted to match the locomotives actual operating environment. Even when driving uphill and downhill, the sounds change to accurately reflect prototypical operation. When the locomotive is supposed to start, the sound module will stop the motor from working (via the decoder), until the actual starting of the vehicle synchronises with the sound of the motor. A diesel locomotive, for instance, roars right before it starts. The decoder stops the train from moving until the roaring is over and the motor sound begins. If the locomotive is stopped, the appropriate "squealing" brake sound is produced. While stationary, different operating noises for the-respective type of locomotive are produced by chance (coal shovels, compressed air). With diesel locomotives, the engine startup and shutdown sounds can be heard when this function is switched on and off. With the new 4 channel technology the driving (motor) sound of the locomotive, which can be switched on and off using the appropriate function key and 3 more sounds can be triggered by function keys. Here, depending upon the type of locomotive (as displayed in the CV table), whistle, horn, bell, door warning / closing signal or uncoupling sounds can be played. Additional up to 4 individual sounds (wav) can be uploaded and set with the function keys f0 - f28. Steam loco driving sounds can be rendered controlled by speed steps or wheel synchronisation.

If the locomotive runs out of the visible range of a model railway facility, e.g. into a shadow station, then "audio muting" can be softly faded out by a special function key. By pressing the function key again, the sound is gradually faded in, adapting itself to the existing driving conditions (i. e., sound synchronized to the motor speed).

The software "SUSI-SoundManager" (Uhlenbrock item no. 31060) is needed for configuration of individual sounds. Especially how an individual sound will operate (on, loop, off).

The USB sound charging adapter 31080 (USB, incl. SUSI SoundManager) from Uhlenbrock is required to charge all sounds.

Installation of a Sound modul

Connecting the SUSI-interface

Insert the plug with the red, blue, grey and black cable into the appropriate socket of your locomotive's motor decoder. The sound module receives its power and data from the decoder.

Loudspeaker

Each speaker needs a resonator. It is sometimes possible to use the locomotive body or the wagon body as resonator.

Additional Connections

At the underside of the modul are 6 soldering pads for special functions like fire box, steam generator and wheel-synchronized exhaust "chuff" sounds (connection diagram on page 2).

Sound depended Auxiliary functions

Loads that are controlled depending on the sound can be connected to outputs SA1 and SA2. In a steam locomotive a smoke generator can be connected to SA1 and lighting for the firebox to SA2. With an E-Locomotive or Commuter train two lighting types can be connected. To SA1 a simulated brake disc glow or a brake light and to SA2 the flash of a disconnecting power pickup. For Diesel locomotives only output SA1 for a simulated brake discs glow. On the above mentioned loads the second pole is connected to +20V. For LEDs please take note of the polarity.

Extern input for wheel revolution sensors

In order to produce the wheel synchronization to the chuffs of a steam locomotive or curve screeching in an E-locomotive or diesel locomotive, the sound module has a special sensor input. As sensor, a reed switch or a Hall sensor together with magnets on a locomotive wheel (Bogie for curve screeching), or a light sensor with the corresponding markings on a wheel can be used. The reed switch, Hall sensor or light sensor are connected to the solder pads as shown in the diagram.

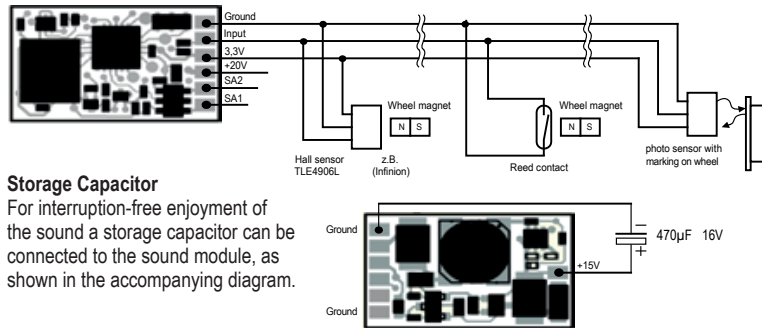
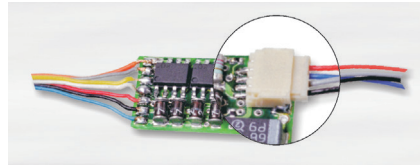

Storage Capacitor

For interruption-free enjoyment of the sound a storage capacitor can be connected to the sound module, as shown in the accompanying diagram.

Attaching the sound module

Using a piece of double-sided "sticky" tape, fasten the sound module to any place in the locomotive. The sticky tape holds the sound module reliably in place and protects it from coming in contact with other wires, components, etc.

Start-up

Make sure that placing the module in the locomotive will not cause a short circuit! Also insure that, once you have replaced the body (shell) of the locomotive no wires are "pinched" which could also cause short-circuits to develop.

A short circuit between engine, lighting, pickup shoe, wheel sets and the module can possibly destroy the decoder's components as well as the electronic of the locomotive!

Switching sounds on and off

The individual sounds can be switched on and off using special function keys on your digital Command Station/ Throttle. The allocation (or mapping) of the various sounds to individual special function keys can be modified using CV's 903 - 915.

Decoders are delivered with sounds initially allocated as indicated in the above table.

Default operation	Typ of Sound	Number of Sound
Special function f1	Motor sound	3
Special function f2	Typhon	2
Special function f3	Uncoupling	4
Special function f4	Bell	1
Special function f5	Conductor wistle short	5
Special function f6	interior lighting drivers cab	-
Special function f7	Announcing departure	11
Special function f8	Mute function	8
Special function f9	Conductor whistle long	12
Special function f10	Warning tone	16
Special function f11	Whistle	17
Special function f12	Horn	18
Special function f13	Station announcement 1	6
Special function f14	Radio message / cab talk	14
Special function f15	Compressed air	13
Special function f16	Brake squeal	97

If the locomotive runs out of sight on a layout, e.g. into the shadow station, the sound can be faded out by the "mute" function with a special function key (f8 in factory default state), switching all sounds off. Internal to the module the sound continues to be issued according to the driving condition. If the sound is faded in again by switching the special function off, the sound will be audible again and matching the driving status.

Volume

Speaker volume can be changed via CV 902. As shipped from the factory, the volume is set to its maximum level.

Configuring the dynamic change of sound

Some settings, which concern the change of the sound in regard to the present driving conditions, can in each case be adapted to the type of locomotive used. The settings concern the change in sound change with loading (uphill and downhill), the speed threshold for starting the brake screeching and switch-on threshold for the electric blower in an E-locomotive. CV 937 A changes the sensitivity to load regulation. If a value of 1 is programmed here, the sound reacts very quickly to uphill and downhill running. A value of 8 results in a delayed reaction. With CV 938 A the trigger threshold for a sound change for uphill driving (Load increase) can be set and with CV 939 A the trigger threshold for a change in sound for downhill driving (Load reduction) can also be set. All values depend on the locomotive decoder and the locomotive used and must be determined by test driving. With CV 936 the speed threshold can be changed and the brake screeching starts when the locomotive speed is reduced. CV 934 sets the speed threshold at which E-locomotives sound the cooling blower is closed. In a steam locomotive the repeat rate of the chuffs can be influenced. In CV 938 the time between 2 chuffs at maximum locomotive speed can be set, in CV 939 for minimum locomotive speed. In both cases, the larger the value in the relevant CV, the longer the time between the chuffs. With CV 937 a time can be set for how long an idle sound in idle running is to be heard. All ex-factory settings are for Uhlenbrock locomotive decoders and preset for H0 locomotives, but can be matched to other vehicles without problems.

Loading new sounds into the module

If the sound in the module is to be changed, then the module must be separated from the locomotive decoder and the SUSI-plug inserted into the socket of the IntelliSound Loading adapter (Part No. 31 080). The operating steps for changing the sound are found in the manual for the IntelliSound Loading adapter. A large selection of various sounds can be found on the internet site "www.uhlenbrock.de".

Loading custom sounds

In addition to the pre-programmed sounds it is possible to add a maximum of 4 custom sounds with the Intelli-Sound Loading adapter. For this you use the Sound program SUSI-SoundManager and your own sounds in wav format.

Controlling several sound or special function modules from a locomotive decoder

Up to three sound or special function modules can be controlled through a single SUSI interface. CV 897 is used to allocate each module's own CV address range, thus allowing each module to be programmed independently. To accomplish this, each module must first be connected individually to the locomotive decoder. Its own CV address range is determined by assigning the value 1, 2 or 3 to CV 897. Once all modules are connected, each can be addressed and programmed within its own CV address range. The CV to be modified will depend on the CV address range as specified in the list of CV's at the end of this document. Please you note that the explanations in the preceding sections refer to CV address range #1 For changing the address range you have to use the congruent CV-addresses for the 2. or 3. address range from the CV table.

Programming

The basis of all the decoder's configuration options is the Configuration Variables (CV's) as in the DCC standard. The Sound module can be programmed with the Sound Loading Adapter, or via a locomotive decoder. When programming via locomotive decoder all methods supported by the locomotive decoder are available. By using an Uhlenbrock locomotive decoder, an PIKO SmartControl_{wlan}, Intellibox, DCC Centre or Motorola centre can be used for programming. When using third party devices please refer to the locomotive decoder programming section of that device's manual.

Programming with the Intellibox

We recommend that regardless of the format the locomotive decoder will be using later on, when it is connected to an Uhlenbrock decoder, it be programmed via the Programming Menu for DCC decoders. For exact detail on the method please read the corresponding chapter in the Intellibox Handbook.

Programming with DCC devices

When using the Programming Menu of your DCC Centre to program the sound module, if it is connected to an Uhlenbrock decoder, program it by the CV direct Programming method. For exact details on the method please read the corresponding chapter in the Intellibox Handbook.

Programming with Märklin* Central Unit

As long as the sound module is connected to an Uhlenbrock decoder all CV's can be programmed with a Märklin center, but not read.

1. Switch Center off and on.
2. Select the address of the decoder and switch the light on.
3. Operate the direction change-over 5 times in quick succession with the stationary locomotive (speed step 0), until the light turns off.
4. Set the speed controller to "zero". The rear light now flashes slowly 4 times.
5. Enter the number of the CV that is to be programmed.