

#36220 American Steam Sound Kit for Analog DC or Digital/DCC



Characteristics

- Operates automatically on either Analog DC or Digital/DCC power
- Authentic full-featured digital steam sound
- 3 Watt Audio Output w/Volume Control
- 3 Amp Capacity Motor Controller
- 5 Volt Output for Smoke Unit
- 5 Volt Outputs for Front & Rear Headlights
- Screw-terminals for easy connection
- Kit includes Sound Decoder Board, Volume, Control, Speaker & Bell/Whistle Trigger
- Designed for installation in PIKO Mogul & 0-6-0.
Easily adaptable to many other steam locos

Specifications

Sound Decoder - Physical Dimensions

Length: 69 mm / 2.72"

Width: 32 mm / 1.26"

Height: 12 mm / 0.48"

Sound Decoder - Electrical Ratings

Maximum Operating Voltage: 27 V DC

Motor Current Capacity: 2.5 A Continuous, 4.0 A Peak

Lighting Output Current: Maximum 500 mA at 5 V DC

Smoke Unit Output: Maximum 500 mA at 5 V DC

Audio Amplifier Power: 3 Watts at 8 Ohms

Speaker

Nominal Size: 6.5 cm / 2.5"

Rating: 8 Watts

Impedance: 8 Ohms

Frequency Range: 20-20K Hz

Waterproof Cone Construction

Note: If choosing a different speaker (for example, to fit a smaller installation space), ensure that the speaker is of 8 Ohms impedance to avoid damaging the audio amplifier. Choose a speaker of adequate wattage rating to avoid damaging the speaker.

Ideal for PIKO G Mogul and 0-6-0 Loco with Tender.

This sound kit is made for easy installation into PIKO steam locomotives, such as the Mogul or 0-6-0 with Tender. These locos have been factory-prepared for this sound kit. This sound kit can also be installed in other PIKO locos, as well as other brands of steam locos, with varying degrees of ease.

The heart of this kit is a state-of-the-art high-quality digital steam sound decoder (circuit board) developed exclusively for PIKO by SoundTraxx®. This sound decoder is "dual mode", enabling enjoyment of the model's numerous sophisticated features on either Analog DC or Digital / DCC operation. The sound decoder senses which kind of power is being supplied to it and responds automatically, with no switches to throw or connections to change

Technical Features

The steam sound decoder performs numerous functions, on both Analog DC and Digital / DCC:

- Motor control – All power to the motor goes through the sound decoder, enabling proper coordination of the locomotive's movement with other operating features.
- Lighting – The sound decoder provides a regulated supply of 5 volts for directional front and rear headlights. The "forward" light illuminates automatically, according to the direction of travel.
- Smoke – The sound decoder provides a regulated supply of 5 volts to the smoke unit for excellent operation even when the loco is standing still or moving slowly.
- Sound – The authentic sounds of a real steam locomotive are digitally reproduced through the powerful 3-watt audio amplifier. All sounds are polyphonic; one sound will never interrupt another.

Steam Sound Effects

The sound decoder includes over ten sound effects. Depending on the effect, these are generated either continuously, automatically, or as controlled by the user.

- Steam Exhaust (Chuff)
- Whistle
- Short Whistle
- Bell
- Air Pump (Compressor)
- Blower
- Brake Squeal
- Brake Release
- Dynamo
- Steam Release
- Coal Shoveling (factory default is set to "on", but can be turned off using a Digital system, for both Analog DC and Digital / DCC operation)

Precautions and Recommendations

Electronic Components

While the parts of this sound kit are meant for installation in trains that are used outdoors as well as indoors, these sophisticated electronic components are not weather-resistant. Once the sound kit is installed in a model, take care to avoid exposing the model to moisture and extremes of temperature. Never immerse the model in liquid or "flood" the sound kit components installed in it!

Electrical Contact

Poor electrical contact causes the vast majority of all operating problems. Ensure that the electrical contact system of the model provides reliable electrical connections to the sound decoder and from the sound decoder to the appropriate components, such as the motor, lights, and smoke unit.

Proper Installation

While the sound kit components are ruggedly designed, high-quality items and the sound decoder includes some internal electronic protection, these components can easily be damaged by improper handling or installation. Incorrect electrical connections can permanently damage the sound decoder and other components. Assuring proper connection is the responsibility of the user. Damage caused by improper connection or handling is not covered by warranty.

Sound Kit Temperature Range

Minimum Temperature: 4C / 40F

Maximum Temperature: 32C / 90F

Note: Sound decoder performance may be affected by combinations of extreme temperature with high power usage.

Installation

Installation in a PIKO Mogul or 0-6-0 Loco with Tender

This sound kit is designed for easy installation into a PIKO Mogul or 0-6-0 Loco with Tender.

Tools Needed

- #1-Tip Phillips Screwdriver
- 1.3mm (3/64") and 2.5mm (3/32") Flat Blade "Jewelers" Screwdrivers
- Wire Strippers or Sharp Hobby Knife (may be needed for stripping wires)
- Heat-Shrink Tube or Electrical Tape
- Soldering Iron and Solder (optional – smoke unit wires can instead be twisted together and insulated with electrical tape)
- Wiring Diagram from Original Loco Instruction Manual

Installation

- Turn the tender upside down on a soft padded surface and support it so that it will not roll off the table. Take care in handling, so as not to damage small parts like handrails and ladders.
- Place the reed switch assembly in its plastic holder and feed the 3 wires through the small rectangular hole in the holder. Position the circuit board with the printed letters facing towards the cover. Secure the cover to the holder using the 2 small screws provided. Then feed the wires up through the small hole in the chassis above the rear tender truck. Loosen the 2 screws holding the rear tender truck side frames to the truck bolster. Save the screws for re-use. Set the mounting lugs of the reed switch holder down on the screw posts at either end of the truck bolster then place the truck side frames back in place. With the reed switch holder "sandwiched" in between the side frames and the bolster, re-insert the screws to secure the side frames to the bolster. Ensure that the truck pivots freely and the wires do not become pinched by other parts.
- Remove the tender body shell by loosening the 6 screws going up through the chassis into the body shell. Save the screws for re-use. Set the chassis upright next to the body shell.

- Using 2 of the screws provided, mount the small volume control circuit board to the mounting posts located inside the tender shell, under the water filler hatch on the tender's rear deck. Ensure that the board is oriented correctly, so that the volume control knob and smoke unit on/off switch are accessible through the water filler hatch on the rear deck of the tender shell.
- Attention! On early production PIKO #38210 D&RGW Mogul Locos, there are no mounting posts inside the tender for the volume control circuit board. A small block of plastic or even wood can be used as a stable mounting platform to support this circuit board securely and position it for easy access to the controls. Do not leave the circuit board "loose" inside the tender.
- Mount the speaker to the mounting posts in the middle of the tender chassis using the screws provided.
- On the existing main circuit board (located above the front truck of the tender), first make note of the colors and positions of all wires. Next, loosen the screw-terminals part way to allow disconnecting all the wires. Remove and save the small screws which hold the circuit board to the chassis.
- Place the sound decoder circuit board in the location of the old circuit board and, after ensuring that the board is oriented correctly according to the diagram, secure it with the same screws.
- Referring to the wiring diagram, connect all wires to the sound decoder and gently but securely tighten the screw-terminals.
- Attention! The black wire from the loco-tender connector plug and the black wire from the LED rear light must be joined together and connected to the "+5V" screw-terminal. All other screw terminals on the sound decoder should have no more than one wire connected.
- Attention! Check against the wiring diagram again to ensure that all wires have been connected to the correct terminals on the sound decoder. After checking, place the main body shell back onto the chassis, ensuring that no wires are pinched in the process. Hold the chassis and shell together, turn the tender upside down and secure the shell to the chassis using the original screws. Set the tender aside.
- At the front of the locomotive, gently pull on the front panel of the boiler/smokebox to remove it. Take care not to damage the headlight wires.
- Note the small voltage regulator circuit board just inside the front of the boiler. The board is secured to the metal weight with double-stick tape. The board will no longer be needed in this loco. It may be removed from the loco or simply left in place and "bypassed".
- Note the two wires coming into the board from further back inside the boiler. These are the power wires. Loosen the screw-terminals to allow disconnecting these wires.
- Note the two wires which go out of the board and run up into the smokestack. These are the leads of the smoke unit. Disconnect these wires from the board as well.
- Connect one of the smoke unit leads to one power wire. It does not matter which one. Then connect the other smoke unit lead to the other power wire.
- Twist or (recommended) solder the connections to make them secure. Thoroughly insulate the connections with electrical tape or (recommended) heat-shrink tubing. Ensure that the insulation will not come loose and expose bare wires. This can cause a short circuit and possible damage to the loco or sound decoder. Do not operate the loco without these connections properly insulated.
- Press the front panel back in place on the boiler, ensuring that no wires are pinched in the process.
- The loco and tender are now ready for operation on either Analog DC or Digital/DCC power.

Installation in Other Locomotives

The sound kit can also be installed in other types and brands of locos. The wiring diagram identifies all the terminals on the sound decoder circuit board.

PIKO 0-6-0T Saddle-Tank Steam Loco or BR 80 Steam Loco

This installation is relatively easy. These locos have mounting posts for the sound decoder inside the boiler and a place for the reed switch assembly under the front of the gearbox. The sound decoder will power the existing LED lights. For functioning smoke, a PIKO #36142 5-Volt Smoke Unit is required. The sound decoder will power the smoke unit. For proper installation to the speaker mounting in these locos, use a smaller speaker, such as Visaton model FRS 5. Be sure the speaker used is an 8 Ohm model with a capacity of at least 3 Watts. The volume control circuit board may be mounted inside the loco cab or in the front of the boiler using double-stick foam tape.

Other Locos

No instruction manual could cover all the possibilities, but the compact size and simple screw-terminal connections of the sound decoder enable it to be installed in a wide variety of G-Scale steam locomotives and even many 2-Rail DC/DCC O-Scale steam locos. Of course, such installations should only be performed by someone with the knowledge and technical skills to complete the job successfully. And the installer assumes all responsibility for a proper installation without harming the components or the model.

Installation Precautions & Recommendations

Proper Connections

It is essential to assure that all connections are made correctly. Improper connections can damage components of the sound kit or the locomotive, which is not covered by warranty.

Power Feedback

Attention! It is extremely important to ensure that no track power, battery power or other power source can "feed back" into any of the sound decoder's outputs! This will damage the decoder! This sort of damage is recognizable and is not covered by warranty.

Unlike other sound units, which may simply need connection to a supply of power, the sound decoder in this kit must be inserted "inline" between the power supply (track power pickups, battery power, etc.) and the loco's motor, lights and smoke unit. All power for the motor, lights and smoke unit must pass through the sound decoder. On many locomotives, there may be multiple power supply paths. Locating and isolating all of them can be challenging. Therefore, it is critical to test and re-check to be sure that all possible sources of power feeding back into the sound decoder have been completely and reliably eliminated.

Proper Mounting and Insulation

Take care to insulate all wiring connections properly and ensure that the insulation will not come off the connection. Do not mount the sound kit components to metal surfaces. This will cause short circuit damage to the components. Mount the sound decoder, speaker, volume control and reed switch assembly securely to stable surfaces, with screws, using the provided mounting holes. Do not mount these components with foam tape or other adhesives which can come loose.

Mount the sound decoder using insulating "stand offs" to provide clearance under the circuit board for air circulation and to ensure that the sound decoder cannot touch any metal surfaces.

If using the reed switch assembly to trigger bell and whistle signals, mount it sufficiently far away from magnets, such as motors and speakers, to avoid unwanted triggering of the reed switch contacts. The magnet of the speaker included in the kit is strong enough to interfere with the reed contacts even at a distance of 6 to 7cm (2.5 to 3").

Ensure that the installation will protect the sound kit's components from extremes of heat, cold and moisture. Do not mount the components near heat sources, such as motors and smoke units.

Do not exceed the limits of any of the sound kit's components, as listed in the "Specifications" section.

Analog DC Operation

The sound decoder is designed to be fully functional and ready for installation right-out-of-the-box. For many locomotives, such as the PIKO Mogul and 0-6-0 Loco with Tender, no adjustments should be necessary after installation. Proper installation will leave the loco completely prepared for optimal operation on either Analog DC or Digital/DCC. *For operation using a Digital / DCC system, refer to the section labeled "Digital / DCC Operation".*

Power Supply

Attention! The sound decoder should only be operated on a high-quality, electronically-regulated power supply providing 0 to 24 volts of smooth, filtered DC, with a capacity of at least 2 Amps and a fast-acting fuse or circuit breaker to protect against short circuits. Do not use a power supply which is not in safe and perfect working condition. Older rheostat-style power packs and "pulse" or "pulse width modulation" power supplies will result in erratic and unreliable operation and should not be used. The use of an improper power supply can even damage the sound decoder and void the warranty.

Depending on the quality of the voltage from the power supply, some automatic sound functions may not work correctly or may trigger continually. The sensitivity of these functions can be adjusted using a Digital / DCC system. See the Owners Manual for further information.

Attention! Do not exceed the sound decoder's absolute maximum input voltage rating of 30 volts. If the input voltage exceeds 29 volts, the sound and motor will automatically shut off and the front and rear lights will flash. Decrease the voltage immediately! The sound decoder will recover at approximately 27 volts.

Operating the Model

(Note: These operating instructions are written for a sound kit installed in a PIKO G Mogul or 0-6-0 Loco with Tender. For other locos, the same operating principles and features apply, but some adjustments may be needed for optimal performance. For example, the motor starting voltage may need to be set higher or lower, or the exhaust "chuff" rate may need to be adjusted for different gearing and drive wheel diameters.)

With the throttle set to zero, the locomotive will be motionless and silent, as it has no power. Turn the throttle up gradually to about 5 to 7 volts to provide sufficient voltage to power up the internal circuitry of the sound decoder. At this point, the sound of the dynamo (generator) will be heard, as well as the steady sound of the blower and the occasional random pumping of the air compressor. The smoke unit will begin to work and the appropriate headlamp (front or rear, according to the direction of travel) will be lighted. If the throttle is set to move the locomotive forward, two blasts of the whistle will sound as the throttle is increased. If it is set to move the locomotive in reverse, three blasts will sound. At start-up in either direction, the bell will sound for about 5 seconds.

Increasing the throttle further to about 8.5 to 9 volts will set the locomotive in motion, increasing speed as the throttle is increased. The exhaust chuff is synchronized to the speed of the locomotive. As the throttle is increased and the loco begins to move, the bell will automatically start and ring for about 5 seconds.

For best operation, adjust the throttle smoothly and gradually. Erratic movement of the throttle can produce poor operation.

When the throttle is turned down, the sound of the brakes squealing will be heard. A bit of practice may be required to learn the rate of throttle decrease which consistently triggers the brake sound. Turning the throttle down further will bring the locomotive to a stop, followed by a single blast of the whistle and the hiss of steam. If the polarity of the input voltage is reversed (i.e. by changing the power supply's direction switch) too quickly or without reducing the voltage below the operating threshold of the sound decoder (about 5 volts), the loco may not change directions and the whistle signals may not be coordinated with the direction of travel.

Leaving the throttle set to provide about 6 to 7 volts to the sound decoder will keep the sounds, lights and smoke operating while the locomotive is stopped, such as while standing at a station. A bit of experimentation will reveal the proper throttle setting to provide operation of these "standstill" features. After a time, the sound of the air compressor pumping will be heard randomly. As set from the factory, the occasional sound of the fireman tossing

a shovel or two of coal into the loco's firebox will also be heard. This occurs about one of four times when the loco stops. (The coal shoveling can be switched off and the probability of the sound occurring can be changed, using a Digital system. The setting will remain in effect on either Analog DC or Digital / DCC operation.)

Triggering Bell and Whistle Sounds

The sound kit includes a sensor (reed switch assembly) to trigger bell and whistle sounds when the loco passes over track magnets (such as PIKO #35268, available separately). The sensor is made to mount on the rear tender truck of the PIKO Mogul or 0-6-0 Loco with Tender. Rotating the track magnet 180 degrees will select triggering either the bell ringing for about 5 seconds or a grade crossing whistle signal (two long blasts, one short, one long). See the instructions packed with the magnets for magnet placement.

Volume Control & Smoke Unit Switch

The sound kit's volume control is made to fit in the tender of the PIKO Mogul or 0-6-0 Loco with Tender, under the water filler hatch cover on top of the rear deck. Pull up gently on the hatch cover. Use a small flat-blade screwdriver and turn the knob carefully to adjust the volume level.

On the same small circuit board with the volume control is an on/off slide switch for the smoke unit. Although the PIKO smoke unit is made to run "dry" with no harm, there may be a desire to turn the smoke unit off manually using this switch. (On Digital operation, this switch must be in the "on" position for the smoke on/off function of the Digital control to work.)

Attention! Always put the hatch cover back in place! Leaving the model exposed to the elements with the cover removed can cause damage to the sophisticated electronic components inside the tender.

Analog DC Features Requiring a Digital / DCC System for Programming

The sound kit is optimized from the factory for best operation under most circumstances, when installed in a PIKO Mogul or 0-6-0 Loco with Tender. Advanced users of Analog DC may wish to make use of a Digital / DCC system to change some of the many programmable functions. Once programmed on a Digital system, most of these functions will also operate on Analog DC. For example, using a Digital system, one of three different whistle tones can be chosen and this selection will remain in effect when operating on Analog DC power.

Digital / DCC Operation

The main component of this sound kit is a sophisticated digital steam sound decoder which has been factory-programmed and optimized. When installed in a PIKO Mogul or 0-6-0 Loco with Tender, the loco is ready for initial use with no need for adjustments or programming. The loco will operate immediately using a PIKO Digital System or other NMRA/NEM-compliant DCC system designed for G-Scale trains. Other locos may require some programming for optimal operation. The sound decoder is not designed to operate correctly on older digital systems (MTS I, etc.) which use only "serial" data transmission. Because the sound decoder also operates the motor, smoke unit and lights, many settings (called Configuration Variables or CVs) can be adjusted to modify how the locomotive runs as well as how it sounds.

For additional information on these features, see the complete Owner's Manual and Technical Reference at www.piko.de or www.piko-america.com. Note that a computer with Adobe® Acrobat Reader installed is required to view and print these files. This is available as a free download from www.adobe.com.

Operating on the PIKO Digital System or other DCC system

The sound decoder is factory-programmed to respond to Loco Address 3. The online Owner's Manual provides the information needed to adjust the sound decoder's numerous settings (CVs) as desired.

Attention: The sound decoder is a highly sophisticated and technically complex device. The factory-programmed settings (CVs) are the result of extensive engineering experience and testing for optimal performance. Changing CVs can result in poor performance or failure of some functions to operate. This should only be attempted by someone technically qualified to perform these tasks successfully.

The sound decoder is factory-set with the following "default" function assignments:

| Function | Default Setting |
|----------|--|
| F0 | Headlight On/Off |
| F1 | Bell On/Off |
| F2 | Whistle On/Off |
| F3 | Short Whistle |
| F4 | Steam Release (Hiss) |
| F5 | (Not used) |
| F6 | Smoke Unit On/Off |
| F7 | Headlight Dimmer On/Off |
| F8 | Mute |
| F9 | Inertia Override (temporarily overrides momentum settings) |
| F10 | Half Speed (for switching/shunting operations) |
| F11 | Brake Squeal (when moving) Brake Release (when stopped) |
| F12 | (Not used) |

Automatic versus User-Activated Features

Some features work automatically on Digital operation, for example, steam exhaust chuff, air compressor and coal shoveling (as appropriate for the loco). Other features, such as bell, whistle and brake sounds, are user-activated by the appropriate function button on the Digital controller.

Volume Control

The volume control knob also functions on Digital operation. (See section above under Analog DC Operation for important info.) Additionally, using a Digital system, the sound decoder's built-in mixer allows adjustment of the master volume as well as individual adjustment of each sound effect. The Owner's Manual provides info on these settings.

Track Magnets

If track magnets are installed in the track, the included sensor (reed switch assembly) can activate the same bell or whistle sequences described above under Analog DC Operation.

Popular CV Adjustments

Loco Address

Using a Digital system, the address of the sound decoder may be programmed to any address ranging from 0 to 9,999. Note that some Digital systems can only program or operate a more limited number of addresses.

Speed Steps

The sound decoder is factory-set to 28 speed steps. It can also be programmed to either 14 or 128 speed steps. If operating on a system which only supports 14 speed steps, it will be necessary to program the sound decoder to 14 speed steps for proper functioning of the headlights.

Whistle Tone

By programming CV 115 to a value of 0, 1 or 2, one of three different whistle tones can be selected.

Coal Shoveling

The factory default for CV 201 is a value of 64, which produces coal shoveling sounds about one of four times when the loco stops. For models of non-coal powered locos, the coal shoveling may be turned off by programming this CV to a value of 0.

Speed and Chuff Rate Adjustments

Especially when installing the sound kit into various other locomotives, it may be desirable to adjust things such as the motor starting voltage, maximum and midpoint voltage and the exhaust chuff rate.

- **Motor Starting Voltage**

CV 2 sets the voltage that is supplied to the motor at Speed Step 1. CV 2 may be programmed with any value between 0 and 255. Each step in the CV value corresponds to about 0.4% of the maximum available motor voltage.

- **Maximum and Midpoint Voltage**

CV 5 adjusts the maximum voltage that is supplied to the motor. CV 5 may be set to any value between 2 and 255, with 255 supplying the motor essentially 100% of whatever voltage is supplied to the sound decoder. CV 6 works similarly, but sets the motor voltage at the midpoint of the speed step scale. For a linear response, CV 6 should be set to exactly half the value of CV 5. For example, if CV 5 is set to 204, CV 6 should be set to 102.

- **Exhaust Chuff Rate**

The sound decoder uses an Auto-Exhaust Chuff synchronization feature, controlled by CV 116, to produce an engine exhaust chuff rate in proportion to the throttle setting. This avoids the complexity of "chuff sensor" devices installed on locomotive axles, while producing exhaust chuffs which are matched to the loco wheel rotation closely enough to satisfy most operators.

To adjust the chuff rate, begin by setting the starting voltage (CV 2) such that the loco barely begins to move at Speed Step 1. Then, with the loco traveling slowly, adjust CV 116 up or down as needed (between values of 0 and 255) until the chuff rate is approximately 2 or 4 chuffs per wheel revolution, as desired. 4 chuffs is "prototypical", while 2 chuffs is an alternate preferred by many G-Scale and O-Scale train operators, particularly those who like to run trains relatively fast.

The Owner's Manual provides details on a more sophisticated procedure for setting the chuff rate to more accurately match the locomotive's speed throughout the throttle range

CV Reset

Programming CV 8 to a value of 8 will accomplish a "reset" of all CVs to the factory defaults.

Further CV Adjustments and Detailed Info

The sound decoder is a sophisticated device with a long list of possible adjustments. See the complete Owner's Manual online at www.piko.de or www.piko-america.com for complete details on CV adjustments.

Assembly instruction
Mogul Tender

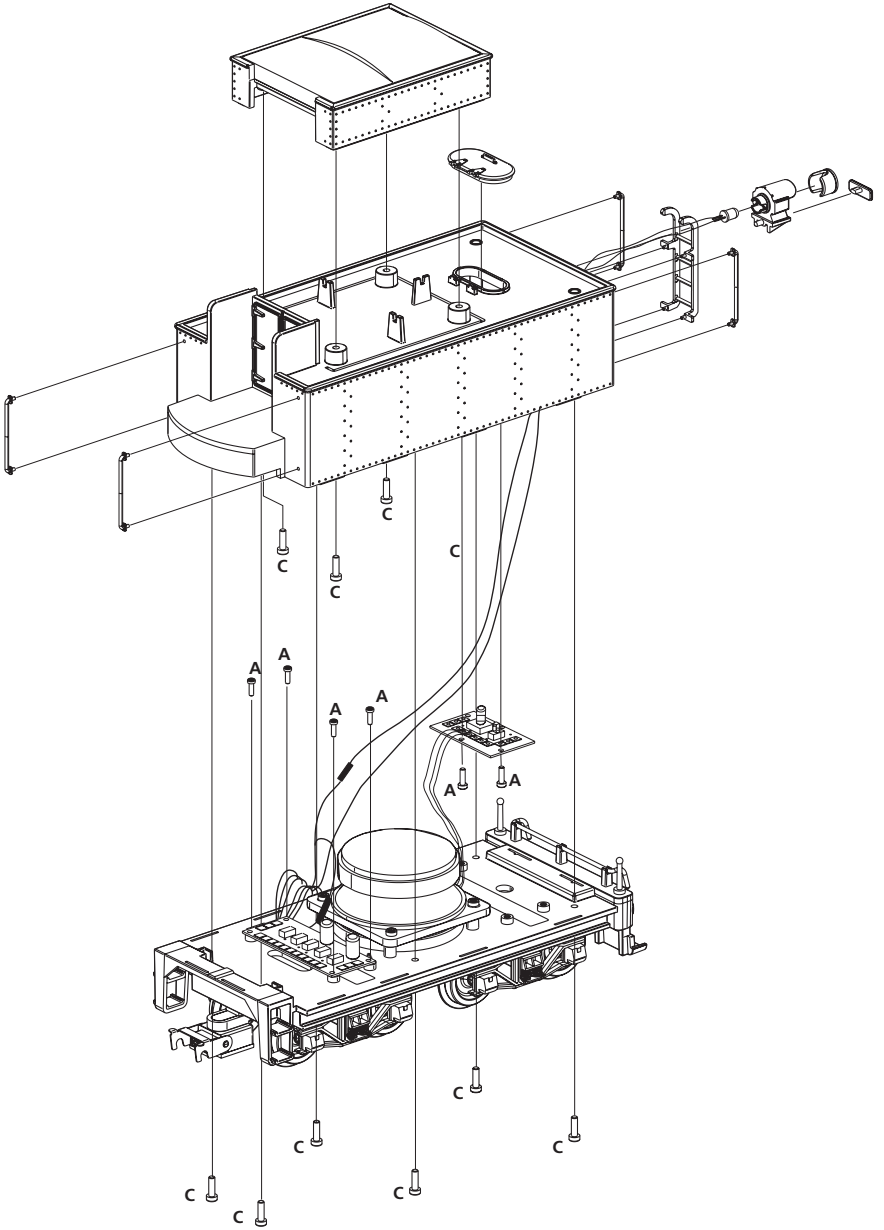

36220 Sound Kit Connection Diagram

