

# PIKO digital Manual

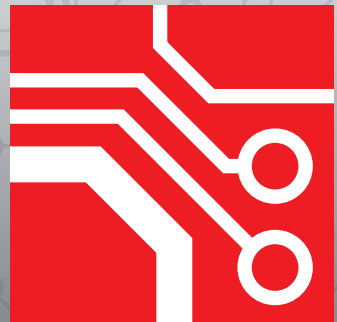



**PIKO digital**

## Getting off to a quick start :

1. Connect the adapter and the Digi 1 as described on page 8 under "Connection and Operation".

2. The locomotives in the start set have been allocated addresses, which are shown on the labels on the bottom of the locos together with the transmission channel for the PIKO Digi remote control.

3. Put the loco on the track and note the address and transmission channel (see label on bottom of loco). To start the loco all you have to do is to press one of the keys "A" to "D" on the remote control corresponding to the transmission channel given on the bottom of the loco. Then you can regulate the speed directly by pressing the keys "+" or "-". If you press  or  while the model is in motion it does an emergency stop and changes direction. We recommend you practise this a few times to give you reliable control of the loco speed.

4. If you want to run another loco with a different address (see label on the bottom of the loco) on your layout then proceed as follows:

Stop the loco in operation and put the second loco on the rails. You can control this loco exactly like the first one by using the appropriate transmission channel keys channel "A" to "D". Please practise this a few times.

If you want to run both locos then press the appropriate transmission channel key ("A" to "D") for the loco in question and regulate its speed and direction as described under point 3 above.



That is the whole secret of digital control.

Congratulations! you have mastered it already!

**5. N.B.:** if you have problems with running two locos e.g., if the two locos are heading for a collision, press the "Stop" key immediately.

Remove one loco from the rails, then press the Stop key again and start again from the beginning as described above.

If you press the Stop key for a second time before removing the locos from the rails they will start moving again at the same speed and - the crash is inevitable.

6. A better way to control the locos is as follows: to bring a loco to an emergency stop it is safer first to press the channel key "A" or "B" for the loco and then either  or . This also stops the loco.

You should practise this a few times.

Engine drivers on the full-size railways aren't let loose on the passengers in the first five minutes either. It simply takes practice!.

Enjoy your training - it's certain to be a success!

First of all we should like to congratulate you on acquiring your new PIKO Digital Start Set. You have taken a decisive step into the fascinating world of PIKO model railways.

Since you have decided on a digital system, unquestionably the modern way for running model railways, we should like to help you with some information that is important for you and which will provide you with the basic knowledge necessary for using digital technology.

You do not need to know anything about digital technology. Just as you don't need to know why your computer does what you want - or sometimes doesn't! At the beginning it is enough if the locos run the way you want and later, in a second step, you learn how to set the switches.

It is a good idea to find a helpful dealer specialising in model railways who can advise you when it comes to extending your new PIKO layout and from whom you can purchase the extra PIKO products you need.

But before we explain how to set up your layout, we should like to give you some general information.

## **Analogue versus digital**

### **A fundamental decision**

PIKO model railways give you lots of fun regardless of whether they are operated by the conventional adapter and controller or by digital controls.

The conventional method of operating model railways is known as analogue technology. It provides endless possibilities for large and small layouts. At the same time it has the advantage of being very sturdy and, especially for beginners, it provides simple access to the functioning of electric models. It is neither outdated nor antiquated nor old-fashioned.

Digital technology is a bit more complicated since it includes various control and receiver components. Owing to its potential complexity it necessarily requires more knowledge for its operation since the functions of the locos as well as many other accessories can be controlled separately. The essential advantage of digital technology is that it is possible to control several locomotives on one track at the same time.

An analogue layout can be converted to a digital layout without difficulty. Rails, turnouts, locos and wagons can all be operated digitally. However all the components to be controlled must be provided with a data receiver, known as a decoder. This converts the digital commands received into analogue current. Even on a digital layout the movements of the locos, turnouts and signals are made via analogue driven motors.

Conversely operating a digital layout with analogue technology is also possible, but a fair amount of alteration to the wiring is needed and there is no point - digital is so much more versatile.

This means that if a PIKO model rail enthusiast has decided on digital technology, he or she should if possible keep to this technology.

Owing to its variety of control possibilities digital technology provides enormous enjoyment. You will learn a lot and if the layout is complicated and many trains are to run at the same time you can use a computer to control it - this is not always so simple but can be an enjoyable challenge.

## Analogue and digital technology - the fundamentals

**With analogue technology** the speed of PIKO locos is controlled by the voltage (0 - 14V). This is achieved by a controller such as the PIKO Speed control #55003 (speed control with mains adapter) or the transformer with speed regulator #55002.

With this only one loco can be driven on a track at a time. If several locos are on the same track, they will all travel at the same speed. If the tracks are isolated from one another it is possible to drive several locos but it is then necessary to connect several speed controllers to the tracks with appropriate switching and separate speed controller for each of the locos that will be simultaneously moving.

**With digital technology** the entire layout operates with the same voltage (14V). In order to control the individual locos a control centre is required which sends commands (digital data) to the locos via the rails. So that these commands have an effect in the locos each loco is fitted with a decoder, which receives the commands and converts them i.e. decodes them, hence the name decoder.

Each loco is given an address. So that each loco knows when it is being 'spoken to', each command from the control centre must be preceded by the loco's address. Provided the address is identical with the address of the loco it will know: "watch out, this command is for me." Then the command is decoded, the loco decoder converts the command to an analogue function and the loco moves faster, slower, switches on its lights, whistles or stops.

**Technical description:** The control centre converts the voltage received from the mains adapter to direct current. This is transmitted to the rails via an inverter and associated electronic circuits at a frequency of 10 - 20 kHz.

This high frequency current is converted by the loco decoder to analogue DC current that powers the motor as soon as the relevant command arrives.

## PIKO Digi 1 - introduction

To provide for an easy introduction to digital technology, PIKO, in cooperation with the firm Uhlenbrock, which has had experience for many years in the field of digitally controlled model railways, has developed a digital system which is very simple to operate. This system which is based on the PIKO Digi 1 makes it easy for any PIKO model rail enthusiast to set up a digital layout in easy stages.

The first element required is the **PIKO Digi 1**. This is the digital control unit for the PIKO model rail layout. The PIKO Digi 1 takes over the control of the locos and other components on the model rail layout. In the first phase of construction just 2 - 3 locos can be driven at once since the mains adapter supplied with the PIKO Digi 1 only has enough capacity to operate 2 - 3 locos.

If you want to extend the layout and run more than 2 locos at the same time the PIKO Digi 1 can be supplemented by the PIKO Digi 2. But we will hear more of this later.

If it is intended to build a very large layout to run more than 4 - 6 locos at the same time with a lot of turnouts operating simultaneously and with signals continually in operation, the modeller will need a power source with high capacity because the model rail layout will then need a great deal of current. This can be provided by the **PIKO Digi Power Box**.

It goes without saying that in the next few years the PIKO digital system will be developed beyond these three basic elements to make it possible for model rail enthusiasts to keep upgrading their digital layouts. Apart from this it is possible at any stage of the construction to combine with the Uhlenbrock digital systems.

The various levels of construction are shown in the following diagrams:

### PIKO Digi 1 with one rail circuit:

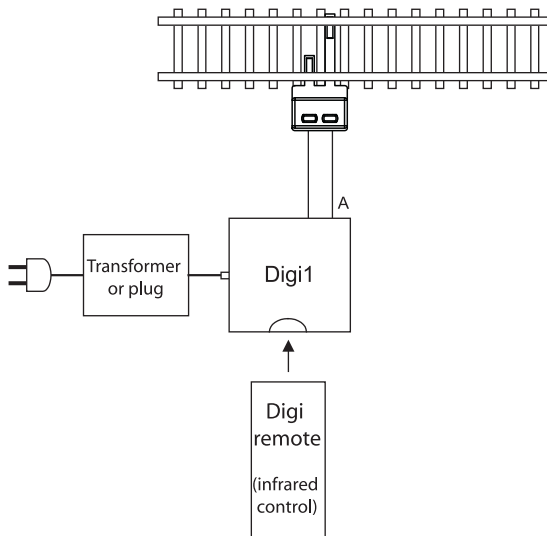

After this the PIKO Digi 1 can be combined with one or two PIKO Digi 2 units:

**PIKO Digi 1 extended with PIKO Digi 2 and two isolated rail circuits:**

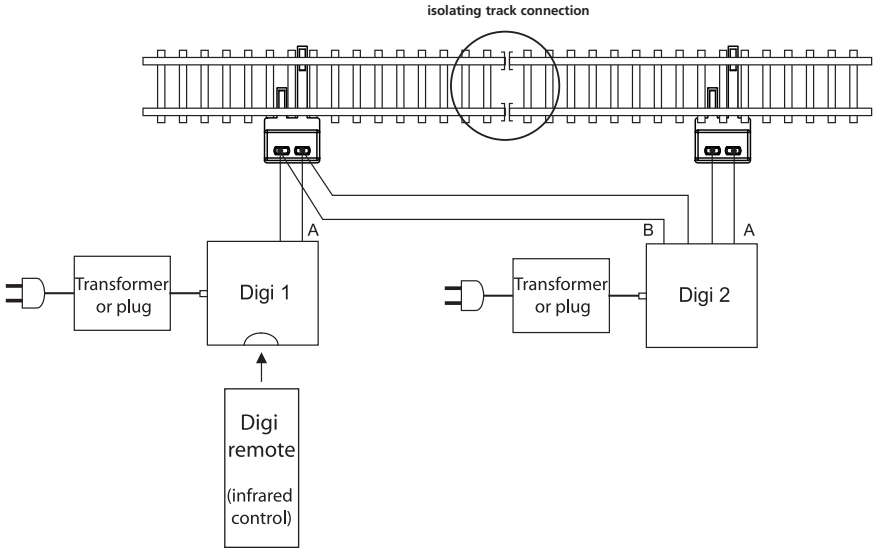

**PIKO Digi 1 extended with two Digi 2 and three isolated rail circuits (maximal level of construction; 10 PIKO Digi 2):**

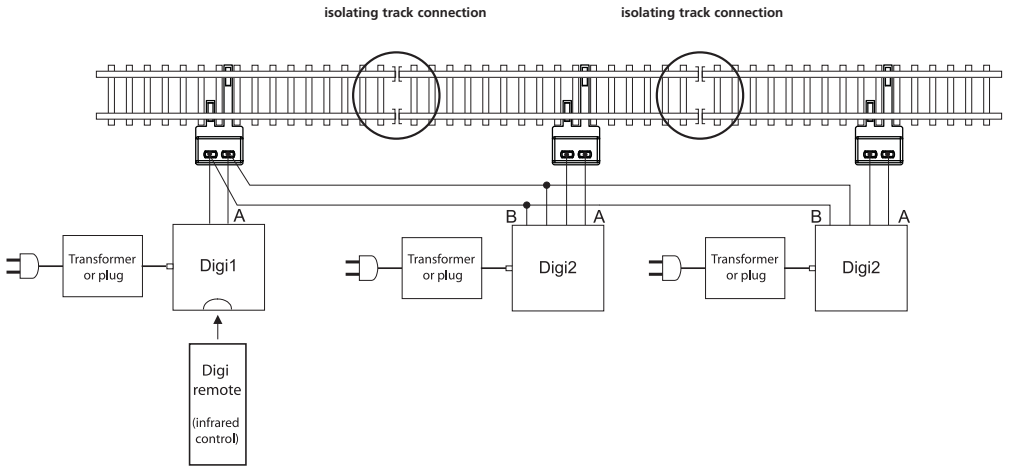

We should now like to explain how to operate the **PIKO Digi 1**, which will of necessity involve rather more technicalities.

## PIKO Digi 1 - the functions

The PIKO Digi 1 is a digital control unit for model railways based on the DCC standard.

The PIKO Digi 1 receives its power from the mains via a mains adapter (transformer) and transmits its commands to the locos via its connection to the track.

The control of the locos themselves takes place exclusively via the infra red remote control, the PIKO Digi-fern (remote control) This transmits the commands to the PIKO Digi 1, which sends them on in turn to the locos.

This means: the control passes from the **PIKO Digi remote control** via the PIKO Digi 1 to the rails and from there to the loco containing the decoder. This then tells the engine: "go faster or slower."

Please note that the PIKO Digi remote control is only suitable for use indoors and that under favourable conditions it has a maximum range of about 10 metres.

With the PIKO Digi remote control and the PIKO Digi 1 a maximum of 127 locos can be addressed on a digital layout and their direction of travel and speed as well as their other special functions controlled. In addition, with the two units, up to a maximum of 256 switches, signals and other electromagnetic accessories can be operated.

To make the PIKO Digi 1 more flexible in its use, the control system has 4 transmission channels which are marked on the PIKO Digi remote control with the keys A, B, C and D. You can store the address of a loco on each of these transmission channels so that it can be controlled when the transmission channel is called up. In addition besides the loco you can switch another 4 electromagnetic accessories via the same transmission channel.

For instance, if channel A controls the loco with the address 15 and the accessories 1 to 4, loco 20 can be controlled using channel B together with the accessories 13 to 16.

Using these 4 transmission channels the modern railroader can switch rapidly from one loco to another. You can carry this even further. If you have several PIKO Digi fern remote control units and use them at the same time (up to 4) each PIKO modeler can control his own loco via one of the four transmission channels without affecting the locos of the other PIKO model train drivers.

## Connection and Operation

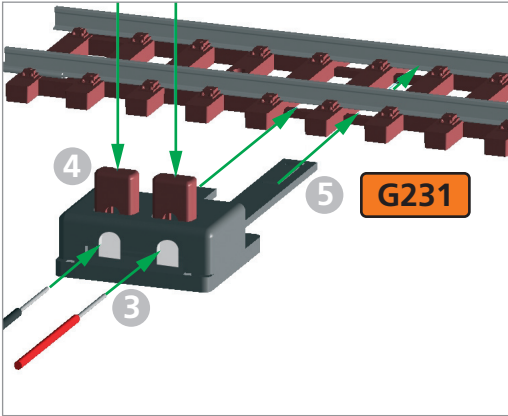

The mains plug (mains adapter) ① is connected via the small plug ② to the socket in the PIKO Digi 1. The two connection leads marked "A" on the bottom of the PIKO Digi 1 are first fixed in the connecting clip ③ by pressing the knobs ④ and are then connected to the rails as follows:

Insert the connecting clip ③ into the rail ⑤ (only this rail has slits between sleepers 5 and 7 for the clip). Now insert the adapter ① into the socket ⑥.

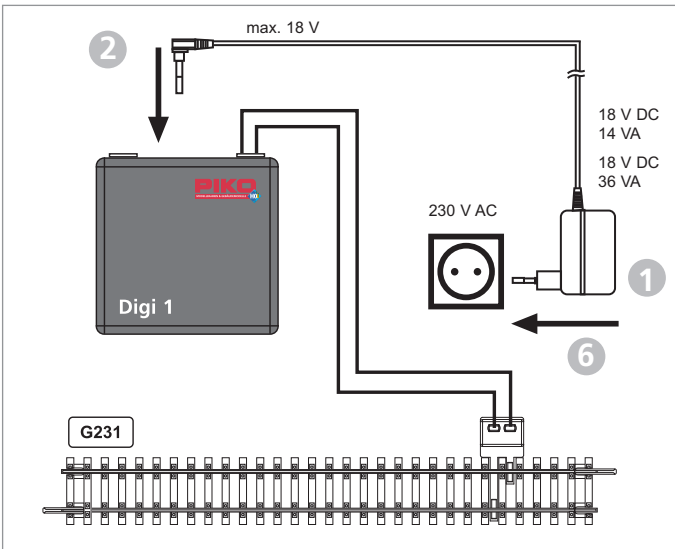

**Please note:** if you are using the PIKO Connecting Clip #55270 then the condenser in the clip **MUST** be removed. If the condenser is left in the Connecting Clip it will eliminate the high frequency control impulses and neither locos or accessories will work.

Next the 4 batteries for the PIKO Digi remote control must be inserted into the battery compartment on the back as described:

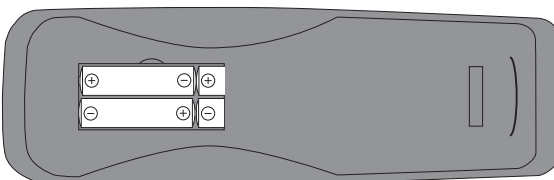

- Batteries of the following types can be used: LR03-AAA-1.5V.
- Remove empty batteries.
- Insert new batteries, observing the correct polarity.
- Do not use new and old batteries together.
- Batteries that are not rechargeable may not be charged.



Now fit the adhesive pad to the base of the PIKO Digi 1. This will fix it to the model rail layout so that the PIKO Digi remote control can always be aimed at the PIKO Digi 1. There must be no obstacle between the PIKO Digi remote control and the PIKO Digi 1 that could block the Digi remote's infra red signals to the Digi 1.

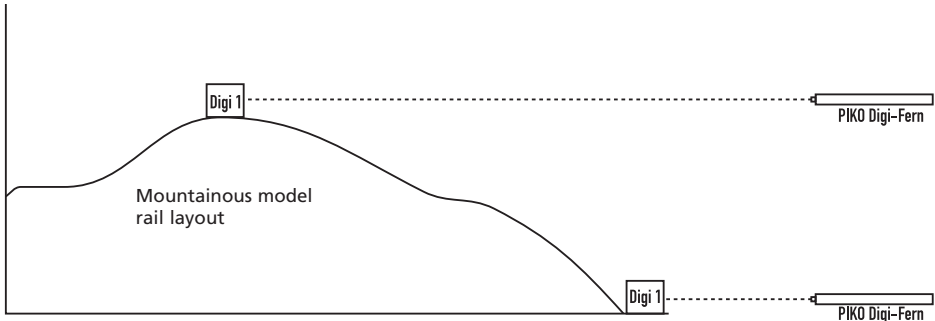

The PIKO Digi remote control works just like your TV remote control, which must also be able to "see" your television.

For this reason when using the PIKO Digi remote control it should always be held pointing towards the PIKO Digi 1 and not towards the loco to be controlled.

A red indicator LED under the transparent dome on the PIKO Digi 1 flashes when the receiver has received the infra red signal from the PIKO Digi remote control.

Problem: no more current available or the locos stop running.

If a short circuit occurs on the track or if the locomotives draw too much current from the track so that the PIKO Digi 1 or the mains adapter is overloaded then one or both units may shut down automatically. You will recognise this by the fact that the locomotives stop running.

If the LED on the PIKO Digi 1 flashes then this unit has switched off:

















- the short circuit must be located and its cause removed or the current requirement for the locomotives reduced (e.g. by removing a loco from the track).
- Switch the PIKO Digi 1 on again using the Stop key on the PIKO Digi remote control. Everything should now carry on normally.

If the LED on the PIKO Digi 1 is not flashing, then the mains adapter has switched off:

- the short circuit must be located and its cause removed or the current requirement for the locomotives reduced e.g. by removing a loco from the track
- The mains adapter will switch itself on again after a short pause. It is not necessary to disconnect the mains adapter from the socket (230 V).

# Using the PIKO Digi-fern remote control



-  control LED shows the current activity in the PIKO Digi-fern remote control
-  stop key to switch the track current on and off
-  loco key to initiate selection of the loco address
-  electromagnetic accessory key to initiate selection of the accessory address
-  key to initiate programming a loco decoder
-  key to increase the loco speed in steps
-  key to reduce the loco speed in steps
-  travel in reverse and emergency stop
-  travel forwards and emergency stop
-  special function switch lights on
-  special function switch lights off
-  keys for the special functions f1 to f4
-  key to select special functions f5 to f8
-  no function
-  keys to switch accessories
-  keys to select the transmission channel

## 1. Control LED

As long as a key is being pressed on the PIKO Digi remote control, the remote control sends an infra red signal.

This activity is shown by the control LED.

## 2. Transmission channel

The PIKO Digi 1 uses 4 transmission channels for the controls. The transmission signal can be altered at any time by pressing one of the keys .

The address of a loco to be driven can be allocated to each transmission channel independently of the other channels.

In addition, 4 individual variable addresses for electromagnetic components can be allocated in each channel to the 4 accessory keys. The addresses selected for each channel are not however stored permanently and are reset as follows when the Digi 1 has been switched off:

When the power is switched on the channels  are always allocated to the loco addresses 1, 2, 3 and 4 and the accessory keys in all channels control magnetic component addresses 1 to 4.

Using the channel keys on the PIKO Digi remote control it is easy to change rapidly between controlling 4 locomotives and 4 groups each consisting of 4 accessories.

If several PIKO Digi remote controls are used each PIKO Digi remote control can select a different transmission channel and so control an individual loco without affecting the loco driven from another PIKO Digi remote control using a different transmission channel.

## 3. Loco control

First of all the transmission channel A, B, C or D must be selected using the keys





### 3.1. Entering the loco address

A loco address must be selected.

To select a loco address press the loco key . The desired loco address can then be entered using the numerical keys 0 to 9

The entry is concluded when any other key is pressed.

This rule does not apply to the channel selection keys . For instance, the entry can be terminated by pressing the key for lights control or a key for altering the speed of the loco.

If on the other hand the loco key , is pressed after the figures have been entered the selection mode is terminated without carrying out the command.

The selection mode is also terminated if no input is made within 10 seconds.

The address used as the loco address consists of the last (up to 3) digits entered provided this address is between 0 and 127. This means you can enter 8 digits if you like but the PIKO Digi remote control only retains the last three. If an invalid address is entered control remains with the previously selected locomotive.

Examples:

1.) input:  [1] [f0]

On the loco with address 1 the lights are switched on.

2.) input:  [6] [5] [4] [1] [2] [3] [+]

The loco with the address 123 increases its speed.

3.) input:  [1] [2]  [f0]

The loco address of the channel remains unchanged and the lights on the previously selected loco are switched on.

Reason: in this example the loco key functions like a delete key i.e. the digits entered are deleted when the loco key  is pressed for the second time and the address entered is not valid.



If the loco address 0 is selected control is directed to a conventional loco without digital decoder - if there is one - on the digital circuit. Thus it is possible to drive a loco without decoder together with the locos fitted with decoders.

### **N.B./Warning:**





If conventional locomotives without decoders are driven with the PIKO Digi 1 in digital operation these locos make a low humming sound because the motor is continually supplied with high frequency current.

This current can damage some engines e.g. bell-armature motors (Faulhaber, Escape etc) and small N motors. On digital layouts these motors should always be used with a digital decoder.



## **3.2. Speed control**

The speed of the loco is increased or decreased in steps with the keys  or . If the keys are held down the speed is altered in steps until either the key is released again, the maximum speed is reached or the loco comes to a standstill.

### 3.3. Selecting the direction of travel



The direction of travel is selected using the keys  or . With the  key the loco is reversed and with the  key it goes forwards. If one of the keys is pressed while the loco is already in motion, the loco is first brought to an emergency stop and then the chosen direction of travel started.

### 3.4. Switching the loco lights on and off

The lights on the loco are switched on with the  key and off with the .

### 3.5. Special functions

The keys  switch the special functions f1 to f4 on and off.

If the dual function key  is pressed and then one of the keys  the special functions f5 to f8 are switched on or off.

If after pressing the dual function key another key is pressed which is not a special function key then the process is broken off.

## 4. Operating accessories

Switches, signals and other items which carry out a function via an electromagnet or solenoid are known as electromagnetic components or accessories for short.

Before an accessory address (using the red/green pairs of keys) can be entered the electromagnetic component key must first be pressed. Afterwards the desired accessory address can be entered using the numeric keys 0 to 9. The first address is always allocated to the outer left red/green pair of keys.

The input is completed by pressing any other key with the exception of the channel selection keys A, B, C and D. For example, the input can be completed by pressing a red or green key or a key for controlling the loco.

If on the other hand after entering the numbers the electromagnetic component key is pressed, then the selection mode is broken off without carrying out the command.

The selection mode is also terminated if no input is made within 10 seconds of the last entry.

The address used for accessories consists of the last (up to 3) digits entered provided this address is between 1 and 256. This means you can enter 8 digits if you like but the PIKO Digi remote control only retains the last three. If an invalid address is entered control remains with the previously selected magnetic component.

Once the accessory addresses have been selected the components can be switched to round (red) or straight (green) using the red and green keys.

The selected accessory address is always allocated to the outer left pair of keys. From here, towards the right, the remaining pairs of keys switch the accessories with the following higher addresses.



Examples:

1.) input:  [1] [red1]

The accessory with the address 1 is switched to red and the accessory keys from left to right switch the accessory addresses 1 to 4.

2.) input:  [6] [5] [1] **[2] [3] [4]** [red1]

The accessory with the address 234 is switched to red and from left to right the accessory keys switch the components with the addresses 234 to 237.

3.) input:  [1] [2]  [red1]

The accessory address of the channel is not altered and the previously selected accessory is switched to red

Reason: after the digits were entered the accessory key was pressed and this breaks off the input.

## 5. Programming loco decoders

### Initial settings of the loco decoders

The loco with the address "1" (see label underneath the loco) is controlled via transmission channel "A".

The loco with the address "2" (see label underneath the loco) is controlled via transmission channel "B".

This can however be altered.

Using the  key a loco decoder can be allocated a different loco address.

**N.B.:** When a loco is re-programmed only one loco should be on the track connected to the power supply. If several locos are on the track all the locos will be programmed to the same address.

To programme the address first the  key must be pressed twice. Then the desired loco address can be entered using the numeric keys 0 to 9. The address used as the loco address consists of the last (up to 3) digits entered provided these are within the range 0 to 127. This means that you can enter 8 digits but the PIKO Digi remote control only retains the last 3 digits. If an invalid address is entered the programming process is not initiated.

If the  key is pressed again after the loco address has been entered the input is completed and the automatic programming process is started.

Examples:

1.) input:   [1] 

Every loco on the track is programmed to address 1.

2.) input:   [5] [6] [1] [2] [3] 

Every loco on the track is programmed to address 123.

3.) input:   [5] [6] [2] [3] 

The programming process is not started because the last 3 digits are 623 and this is not a valid address between 0 and 127.

Every loco which is programmed with the PIKO Digi 1 receives the loco address entered on the PIKO Digi remote control and is switched into the 28 speed mode.

The 28 speed mode represents the levels of speed. This means that the speed is not altered continuously but in small steps. Since these cover the range from approx 2 V starting up current to a maximum of 14 V top speed current, with 28 steps there are so many tiny steps that these do not register as steps at all but seem like a continuous increase in the speed of travel.

The voltage intervals of approx. 0.4V are so small that the modeller cannot tell that it is not a continuous process.

Other features of the loco decoder cannot be programmed.



It is not possible to read information from the loco decoder.

This means that it is not possible to test which loco address has been allocated to the loco on the track. This does not matter, however since the loco or rather its decoder can easily be re-programmed with a new address at any time.

## 6. Power on / off

The current to the tracks on the layout can be switched on and off using the  key.

### Note:

If 10 seconds elapse in selection mode after the keys    are pressed and no other key is pressed, the address input (i.e. loco address, switch address and programming address) is automatically ended. Now the selection mode must be re-started.

The same applies to the dual function key . Here too if 10 seconds elapse after the key is operated and no other key is pressed the process is broken off.

## 7. LED signals

Track current switched on:	LED permanently switched on
Track current switched off:	LED flashes slowly
Short circuit at track exit:	LED flashes quickly
Loco being programmed:	LED flashes twice briefly with longer pause

## Technical data

- Data format: DCC with 28 loco speed levels
- Loco addresses: 1-127, address 0 controls a loco without decoder on the digital circuit (i.e. a conventional loco)
- Special loco functions: lights and f1-f8
- Accessory addresses (turnouts, signals etc): 1-256
- Refresh cycle: 12 locos

**Refresh cycle:** if the power to a loco is interrupted for more than 1 second, the decoder switches to stop. Since this often happens on a layout, the data from the control centre is sent to the locos repeatedly all of the time that the loco is operating. This is called the refresh cycle. The PIKO Digi 1 refreshes a maximum of 12 locos. If more than 12 locos are on the layout it can happen that a 13th loco suddenly comes to a standstill because it hasn't been refreshed. In this case it must be selected again and receive new commands.

- Input voltage: from 14 V to 18 V AC / DC  
(N.B.: none of the power sources must exceed 18 V. If several mains adapters or transformers are connected to the PIKO Digi 1 and the PIKO Digi 2, their voltages must be within the range 14 V to 18 V.)
- Output current: max 1.8A
- Max. power pickup: 45 VA  
(N.B.: mains adapters or transformers of more than 45 VA capacity must not be connected to the PIKO Digi 1 or PIKO Digi 2. Doing so can lead to damage to the electronic components.)
- Mains adapter included #55010 in start sets : max 12 VA
- Power Supply Unit accompanying the PIKO Basis-Set Digital, #55006: max. 36 VA

## Maximum controllable locomotives: two

As described above up to 127 locomotives can be controlled using the PIKO Digi 1.

However, this does not mean that 127 locos can be driven using the mains adapter supplied with the PIKO Digi 1.



Since each locomotive requires a certain amount of current, depending on its type between 300mA and 400mA, and some locos under load (i.e. when pulling a long train) use a lot more, no more locos can be driven at one time than the mains adapter can supply with power. With the mains adapter #55010/NA max. 850mA, included in the start set this would be two locos averaging 400mA.

If more locos are put on the track and too much current is drawn this overloads the mains adapter which simply switches off. This is similar to a short circuit.

## Controlling more than 2 locomotives

If you want to run more than two locos are to be driven on the layout then you must either

- connect a more powerful transformer to the PIKO Digi 1
- or connect extra mains adapters known as boosters to the model rail layout to provide additional power.

**N.B.:** PIKO Digi 1 and PIKO Digi 2 must not be operated using mains adapters or transformers of more than 45 VA capacity. Doing so can cause damage to electronic components and the digital control could be permanently damaged.

## More powerful switching-mode power supply for PIKO Digi 1 The PIKO Power Supply #55006

If you have a start set including a power supply plug (#55010) with a power rating of 850 mA, then you can also increase the power rating of your digital set by exchanging the existing power supply adapter for the PIKO Power Supply #55006. This power supply takes advantage of the full power rating range of the PIKO Digi 1.

### Caution:

Never connect 2 or more power supply adapters at the same time to the same PIKO Digi 1 or to the same Connecting Clip. If you do you will destroy the PIKO Digi 1.

In addition, such simultaneous connection to the plug can result in a deadly level of high voltage for the building's main power supply!

At 18 V DC output voltage, the PIKO Power Supply #55006 delivers a load of 36 VA. This can drive approximately 4 locomotives with power consumption of approximately 400 mA per locomotive on an electrically isolated track section.

Connecting the PIKO Power Supply to the PIKO Digi 1 is done in precisely the same way as with the power supply adapter (refer to the point above entitled "Connection and Handling")

# Additional booster

## The PIKO Digi 2

To increase the power supply to a PIKO model rail layout still further i.e. in order to run more than 2 or 4 locos simultaneously, additional power supply units (transformers) must be connected.

For this PIKO recommends the PIKO Digi 2 with the PIKO Power Supply #55006.

The PIKO Power Supply #55006 can supply power to electrically isolated track circuits through the PIKO Digi 2. Each power supply unit must be connected to a separate PIKO Digi 2. The PIKO Power Supply #55006 uses the maximum power rating range of the PIKO Digi 2.

In order for the digital data from the PIKO Digi 1 to reach the additional electrically isolated track sections, the PIKO Digi 1 must be connected to each of the PIKO Digi 2 units. To ensure that the strength of the signal sent by the PIKO Digi 1 is adequate no more than 10 PIKO Digi 2 units should be connected to one PIKO Digi 1. You should make sure that the length of the lead from each PIKO Digi 2 to the PIKO Digi 1 does not exceed 2 m.

The PIKO Digi 2 is connected to the PIKO Digi 1 via the lead connected to the bottom of the PIKO Digi 2 at exit "B". This lead is connected in parallel to the PIKO Digi 1 connection at the connecting clip on the G231 track.

Using a separate connecting clip the PIKO Digi 2 itself is then connected via the lead at exit "A" to the electrically isolated track section.

The locomotives used can be driven from one electrically isolated track section to another without any problems. They receive their control data from the PIKO Digi 1 which transmits the data via the PIKO Digi 2. Care must however be taken to ensure that the locomotives on a track section at any one time do not require more power than the relevant transformer can supply. Work on the basis of approx. 400 mA per loco. If the locos take up more power than the transformer can supply, it reacts like a short circuit and the PIKO Digi 1 or Digi 2 or the transformer switches off automatically.

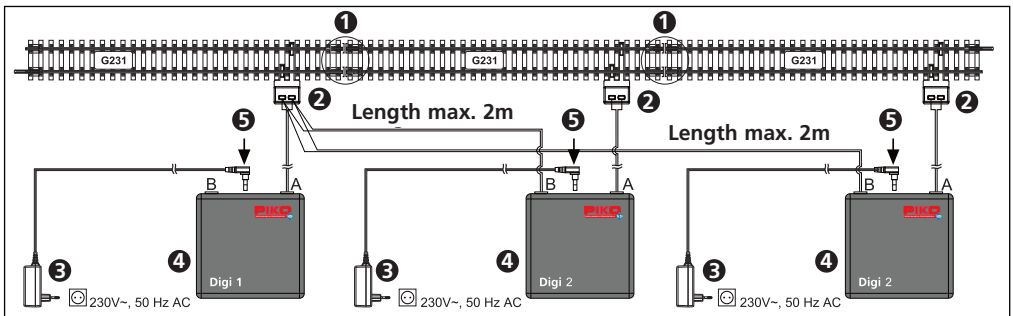

- 1 #55291 Isolating track connection
- 2 #55275 Digital connecting clip
- 3 #55006 Power Supply  
Input: 230 V AC; Output: 18 V DC 36 VA
- 4 A maximum of 10 Digi 2 units can be connected to Digi 1.
- 5 INPUT max.  
18 V / 45 VA AC/DC

If the LED on the PIKO Digi 1 is flashing then the PIKO Digi 1 has switched off:

- the cause of the short circuit must now be eliminated or the power requirement of the locomotives reduced (e.g. by removing a loco from the track)
- The PIKO Digi 1 is then switched on again using the stop key on the PIKO Digi remote control. And now everything proceeds normally again.

If the LED on the PIKO Digi 1 is not on and is not flashing, the mains adapter has switched off:

- the cause of the short circuit must now be eliminated or the power requirement of the locomotives reduced (e.g. by removing a loco from the track)
- The mains adapter will now switch on again after a short interval. It is not necessary to disconnect the mains adapter from the 230 V socket.

**Caution:**

When operating the PIKO Digi 1 using the power supply plug supplied with the set (#55010 - 12 VA) and connecting the power supply plug to a PIKO Digi 2 supplied with electricity by a Power Supply #55006, then it is important that the Connecting Clips (#55275) are connected to the tracks at a distance of at least 1 m apart from each other. If the distance between the Connecting Clips is less than 1 m, operational problems can occur when driving over track separation junctions (short circuit).

This is not required if you use the PIKO Digi 1 with the PIKO Power Supply, #55006 (36 VA) and the PIKO Digi 2 with the adaptor, #55010 (12 VA) or if both the PIKO Digi 1, PIKO Digi 2 are operated with the PIKO Power Supply, #55006 (36 VA).

## The PIKO digital basic set, #55011

If you have a conventional PIKO layout and would like to convert it to a digital layout, you can achieve this with the PIKO basic set.

This contains all the elements required to convert your PIKO model rail layout to a digital system:

- PIKO Digi 1
- PIKO Power Supply (#55006)
- PIKO Digi remote control (#55019)
- Connection clip (#55275)
- 2 PIKO loco decoders with loco addresses 1 and 2

First install the **decoder(s)** in your PIKO locomotive(s). The separate operating instructions for the decoder contain a description. Please note the pre-allocated addresses at the decoder (see the label on the decoder) Unless you alter the addresses first, you need these addresses to control the locos!

Now disconnect the power supply previously in use (transformer or mains adapter with speed control) from your model rail layout.

**N.B.:** It may be possible for you to use your existing transformer as the power supply for your PIKO Digi 1 or PIKO Digi 2. For this it must deliver a constant voltage of 14 V to 18 V AC or DC. The voltage must not fall below 14 V or exceed 18 V.

Nor must the Power Supply have more than **45 VA** capacity.

**At higher voltages the electronic components of the PIKO Digi 1 or PIKO Digi 2 may be permanently damaged!**

Now connect the PIKO Digi 1 to your model rail layout using the connection clip (only possible on G231 track) as described on page 8 above under the section "Connection and Operation".

Connect now the PIKO Digi 1 with the PIKO Power Supply #55006.



## Supplementary digital components from PIKO:

### 55011 PIKO digital basic set

- PIKO Digi remote control
- PIKO Digi 1
- Power Supply, Prim. 230 V AC, Sec. 18 V DC 36 VA
- Connecting clip
- 2 PIKO loco decoders

Only the connection of a switched-mode power supply with max. 18 V AC/DC, 45 VA is permitted.



### 55012 PIKO Digi 2

- PIKO Digi 2
- 4 connectors for isolation rails
- Connection Clip

Only the connection of a switched-mode power supply with max. 18 V AC/DC, 45 VA is permitted.



### 55019 PIKO Digi-fern remote control

- incl. 4 batteries



### 55275 Connecting clip for digital layouts

connecting clip without EMV - suppressor essential for digital layouts fits G231



### 55030 PIKO switch decoder for magnetic components

Switch decoder to switch magnetic components via two independent addresses e.g. turnouts, signals, etc.



### 55031 PIKO switch decoder for electric units

Switch decoder for electric units via two independent addresses such as lamps, motors etc.



### 55006 Power Supply 36 VA

Can be used to supply power to PIKO Digi 1 and PIKO Digi 2  
Input: 230 V AC  
Output: 18 V DC 36 VA



## Table of contents:

Getting off to a quick start	2
Analogue versus digital - a fundamental decision	3
Analogue and digital technology - the fundamentals	4
PIKO Digi 1 - introduction	5
PIKO Digi 1 - the functions	7
Connection and operation	8
Using the PIKO Digi-fern remote control	10
1. Control LED	11
2. Transmission channel	11
3. Loco control	11
3.1. Entering the loco address	11
3.2. Speed control	12
3.3. Selecting the direction of travel	13
3.4. Switching the loco lighting on and off	13
3.5. Special functions	13
4. Operating accessories	13
5. Programming loco decoders	14
6. Power on / off	15
7. LED signals	16
Technical data	16
Maximum controllable locomotives	16
Controlling more than 2 locomotives	17
More powerful Power supply for PIKO Digi 1	17
Additional booster – The PIKO Digi 2	17
The PIKO digital basic set, #55011	20
Any other queries	21
Supplementary digital components from PIKO	22

Owing to the inevitable continuous developments in digital technology we reserve all rights including those involving technical alterations and deliveries. No liability is assumed for the information given. Measurements and illustrations are subject to alteration.

© 2012, PIKO Spielwaren GmbH



PIKO Spielwaren GmbH · Lutherstr. 30 · 96515 Sonneberg, Germany  
Tel. 03675 897242 · e-mail: [hotline@piko.de](mailto:hotline@piko.de) · [www.piko.de](http://www.piko.de)